

# sollas SXP SERIES

**Fully servo-driven,  
flexible, and quick**

**SERVO DRIVEN**

The Sollas SXP is a fully servo-driven overwrapping machine that can wrap up to 80 products per minute. The machine is based on our Sollas SX series, but cam-driven movements are replaced by servo-driven movements. The SXP can package a wide range of products both as single products or as bundles. The change-over time between different products is minimal and the process can be fully automated.

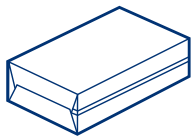

**Overwrapping**

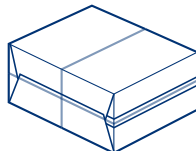

**and bundling**



DIGITAL VERSION



## Your benefits

- ▶ Siemens Industry 4.0-ready
- ▶ Combines excellent wrapping quality with perfect product presentation, giving the consumer first-user guarantee
- ▶ Speed: up to 80/min
- ▶ Large and flexible product size range
- ▶ Self-emptying folding section
- ▶ Trailing edge seal, so no seal on display side
- ▶ Fully servo-driven for minimal maintenance
- ▶ Easy operation through HMI
- ▶ Can handle (bio)film and paper
- ▶ Different infeed directions and bundle infeed systems possible

## Options

- ▶ Fully automatic product change-over
- ▶ Teartape for easy opening
- ▶ Printmark registration
- ▶ Different infeed directions and bundle infeed systems possible
- ▶ Printers
- ▶ Modifications to optimally use coated paper

# Technical details

## Main specs

Max output <sup>1</sup>	<b>60/80 /min</b>
Min product size (mm) <sup>2</sup>	<b>L 40 W 40 (20) H 25 (7)</b>
Max product size (mm) <sup>2</sup>	<b>L 300 W 225 H 96 (125)</b>
Film width range	<b>50 - 435 mm</b>
Film-roll diameter max	<b>400 mm</b>
Air consumption	<b>5 nl / stroke<sup>3</sup></b>
Working pressure	<b>6 bar</b>
Power consumption	<b>6.0 kW<sup>3</sup></b>
Machine approx. weight	<b>1000 kg</b>
Machine color	<b>RAL 9006</b> (Sollas grey)
Drive system	<b>Servo driven</b>
Control system	<b>PLC</b> (Standard SIEMENS, Rockwell or Allen Bradley optional)
Configuration	<b>HL / HR / LL / LIL / DIL</b>
Packaging materials <sup>4</sup>	<b>Polypropylene, coated paper, recyclable BOPP and biodegradable BOPLA</b>

<sup>1</sup>Depending on product and packaging material. <sup>2</sup>Numbers within brackets indication optional changes. <sup>3</sup>Without accessories. <sup>4</sup>In general, all common heat-sealable packaging materials can be used. When in doubt, Sollas will gladly test any material that you wish to use.

## Dimensions

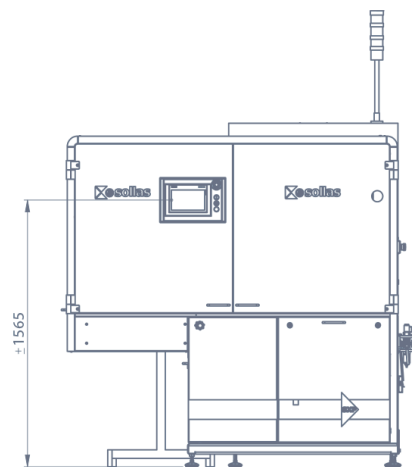
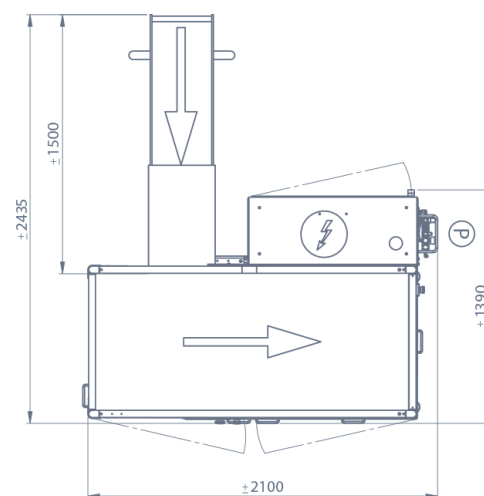

HL configuration

## Sollas signature folding

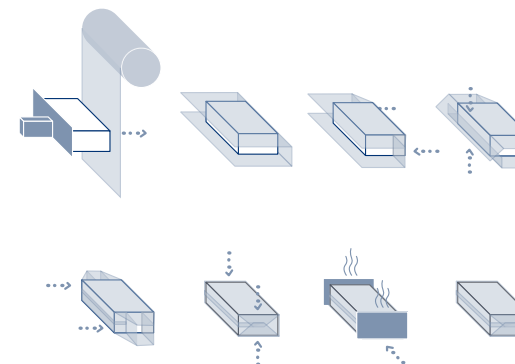

## Product dimension specification

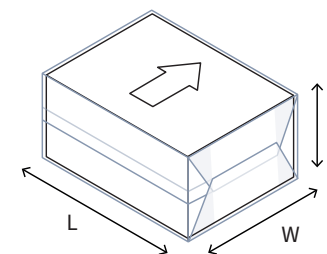

## Conveyor configurations

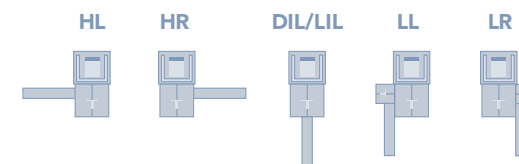



Sollas provides high quality packaging solutions. Our (over) wrapping and banding machines are customized and tailored to each individual situation. Quality and innovation are our keywords. Combined with a reliable service and, above all, a supportive, proactive approach, you can be sure to receive the whole package.



Sollas is a family-owned Dutch company. From our head office in Wormer, we coordinate all our national and international activities. Branch offices are to be found in France, Germany and United Kingdom. Backed by an international network of some 50 agents and distributors worldwide, we provide sound after- sales care and support.

## Interested? Contact us

### Headquarters

Sollas Holland BV, Bruynvisweg 1  
1531AX Wormer, The Netherlands  
[contact@sollas.com](mailto:contact@sollas.com)

[www.sollas.com](http://www.sollas.com)